

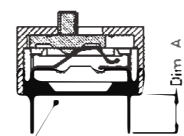

# 拨码开关/按钮 DIP SWITCH, TACT SWITCH & ZIF SOCKET

## KF1001

### How to order

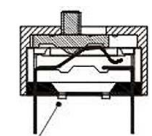
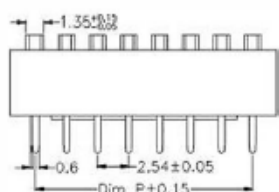
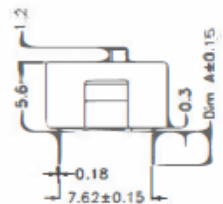
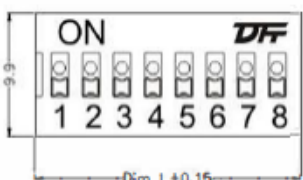
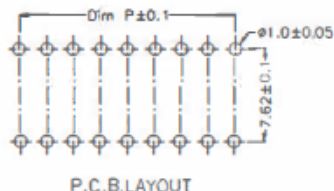
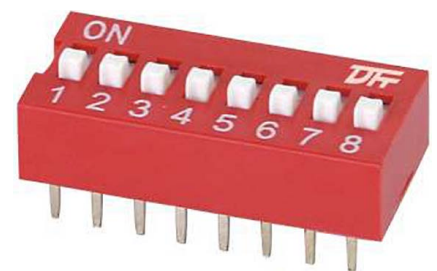
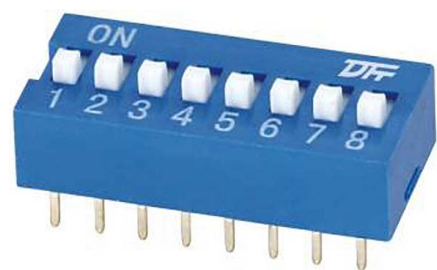
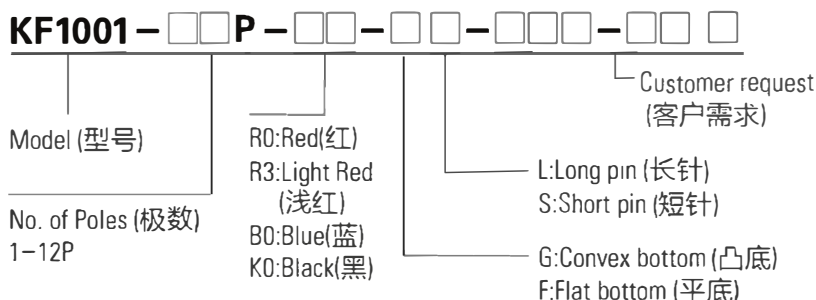

Poles	1P	2P	3P	4P	5P	6P	7P	8P	9P	10P	12P
Dim.P (mm)	~	2.54	5.08	7.62	10.16	12.70	15.24	17.78	20.32	20.86	27.94
Dim.L (mm)	3.96	6.50	9.04	11.58	14.12	16.66	19.20	21.74	24.28	26.82	31.90

Dim.A	S.Short pin	L:Long pin
G:Convex Bottom	2.7mm	3.5mm
F:Flat Bottom	3.0mm	3.8mm

<p><b>MATERIAL</b></p> <p>Base: UL94V-0 PBT Thermoplastic, black Cover: UL94V-0 PBT Thermoplastic, red, blue, black Button: UL94V-0 PA66 White Terminal: Phosphor Bronze, Gold plating</p>
<p><b>ELECTRICAL</b></p> <p>Electrical life: 2000 operations per switch 24VDC, 25mA Non-switching rating: 100mA, 50VDC Switching rating: 25mA, 24VDC The contact impedance: A Initial value of the maximum 50mΩ, B testing after the maximum 100mΩ Insulation resistance: (At 500VDC) 100MΩ/min Dielectric strength: 500VAC, 1 min Capacitance: Max 5pF The loop: Single contact single selection</p>
<p><b>MECHANICAL</b></p> <p>Operating force: 8N(max) Stroke: 2.00mm Operation temp.: -20°C~+70°C Stodge temp.: -40°C~+85°C</p>
<p><b>THE LOOP SINGLE CONTACT SINGLE SELECTION</b></p> <p>For best results, please follow these recommendation: Keep all switch contacts in their 'OFF' position for all operations Wave soldering: Recommended solder temperature at 250±5°C, 3-5 seconds Hand welding: Use 30 watt iron control temperature at 320°C, the welding time is about 2 seconds Cleaning: Cleaning process using ultrasonic method, can give better results, use steam mode, temperature should not exceed 51°C</p>

<p><b>材质</b></p> <p>底座: UL94V-0 PBT 工程塑料, 黑色 上盖: UL94V-0 PBT 工程塑料, 红色, 蓝色, 黑色 推钮 UL94V-0 PA66 白色 端子: 磷青铜镀金</p>
<p><b>电气性能</b></p> <p>电气寿命: 在电压24VDC电流25mA之下测试, 可来回拨动2000次 开关不常切换的额定电流: 100mA, 耐压50VDC 开关经常切换的额定电流: 25mA, 耐压24VDC 接触阻抗: a初始值最大50mΩ, b测试后最大值100mΩ 绝缘阻抗: 最小100MΩ, 500VDC 耐压强度: 500VAC/1分钟 极间容量: 最大5pF 回路 单接点单选择</p>
<p><b>机械性能</b></p> <p>操作力: 8N(最大) 推钮行程: 2.00mm 使用温度: -20°C~+70°C 储存温度: -40°C~+85°C</p>
<p><b>焊接和清洗过程</b></p> <p>在所有操作过程中, 请确保开关在“OFF”位置 波焊: 推荐焊锡温度在250±5°C, 3-5秒钟 手焊: 使用30瓦烙铁控制温度在320°C, 焊接时间大约2秒钟 清洗过程: 清洗使用超声波方式, 能给予更好效果, 使用蒸汽方式时, 温度不可超过51°C</p>